

P.U.D. Plan Urbanistic de Detaliu

REGLEMENTARI EDILITARE

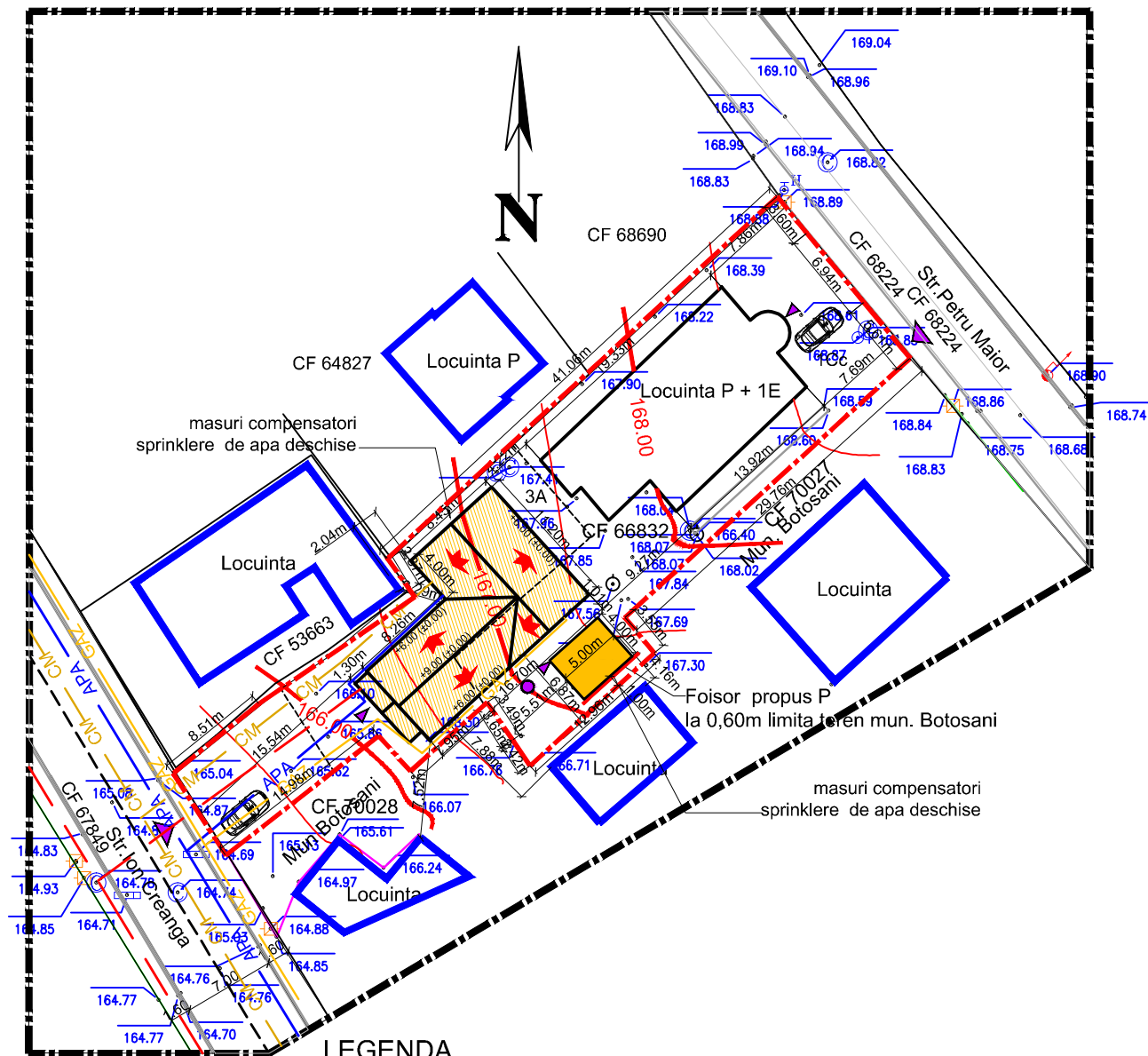

LEGENDA

- Fantana
- Camin apa
- Cutie gaz
- Scurgere apa
- Panou electric
- Limita proprietate
- Constructii

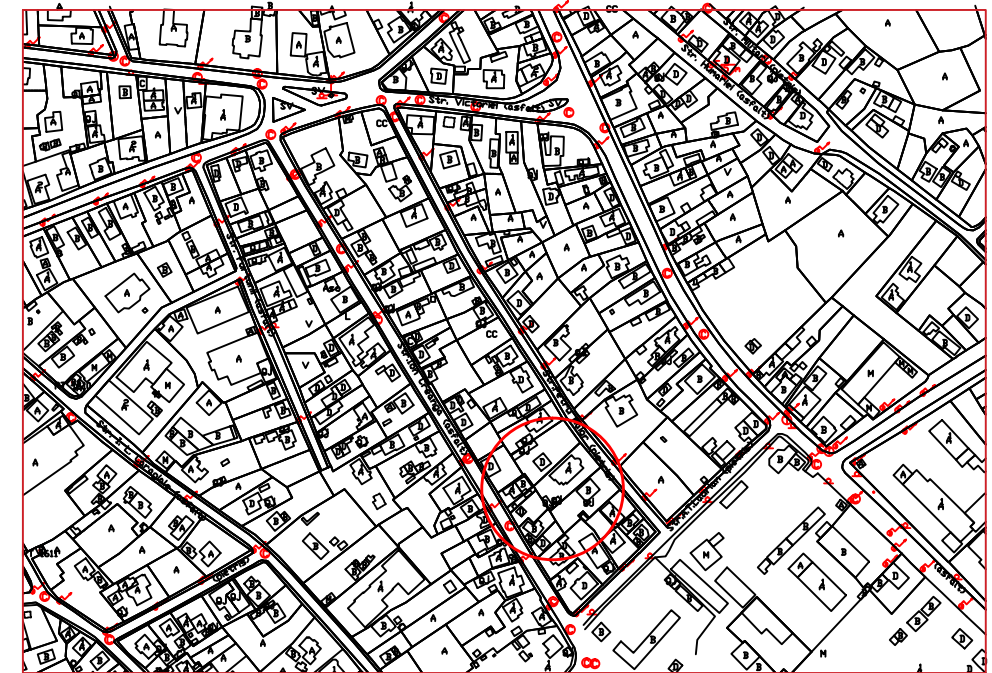

LIMITE

- Limita zonei studiate
- Limita proprietate
- Constructie propusa

REGLEMENTARI EDILITARE

- Retea 0,4KW propusa
- Conducta alimentare cu apa propusa
- Canalizare menajera propusa
- Retea gaz propusa

ZONIFICAREA FUNCTIONALA

UTR nr. 26, LMu1 - subzona exclusiv rezidentiala
(locuinte si functiuni complementare) cu cladiri de tip urban

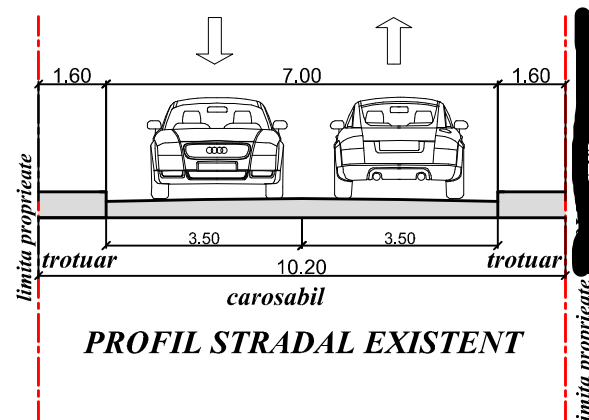

VERIFICATOR	NUME	SEMNAȚURA	CERINȚA	REFERAT/EXPERTIZA NR./DATA
S.C. Centrul de Proiectare si Consultanta Moldova Nord Est s.r.l.	Botosani tel. 0748625588	J07/35/2013 CUI 31149089	Beneficiar: [REDACTED] mun. Botosani, jud Botosani	Proiect nr.: 15/2022
SPECIFICATIE	NUME	SEMNAȚURĂ	SCARA:	Faza:
ȘEF PROIECT	Carh Mihai MIHAILESCU		1:500	P.U.D.
PROIECTAT	Ing. Marian EPURE		DATA:	Planșa nr.:
DESENAT	Tehn.Pr. Remus ISTRATE		2022	U 04